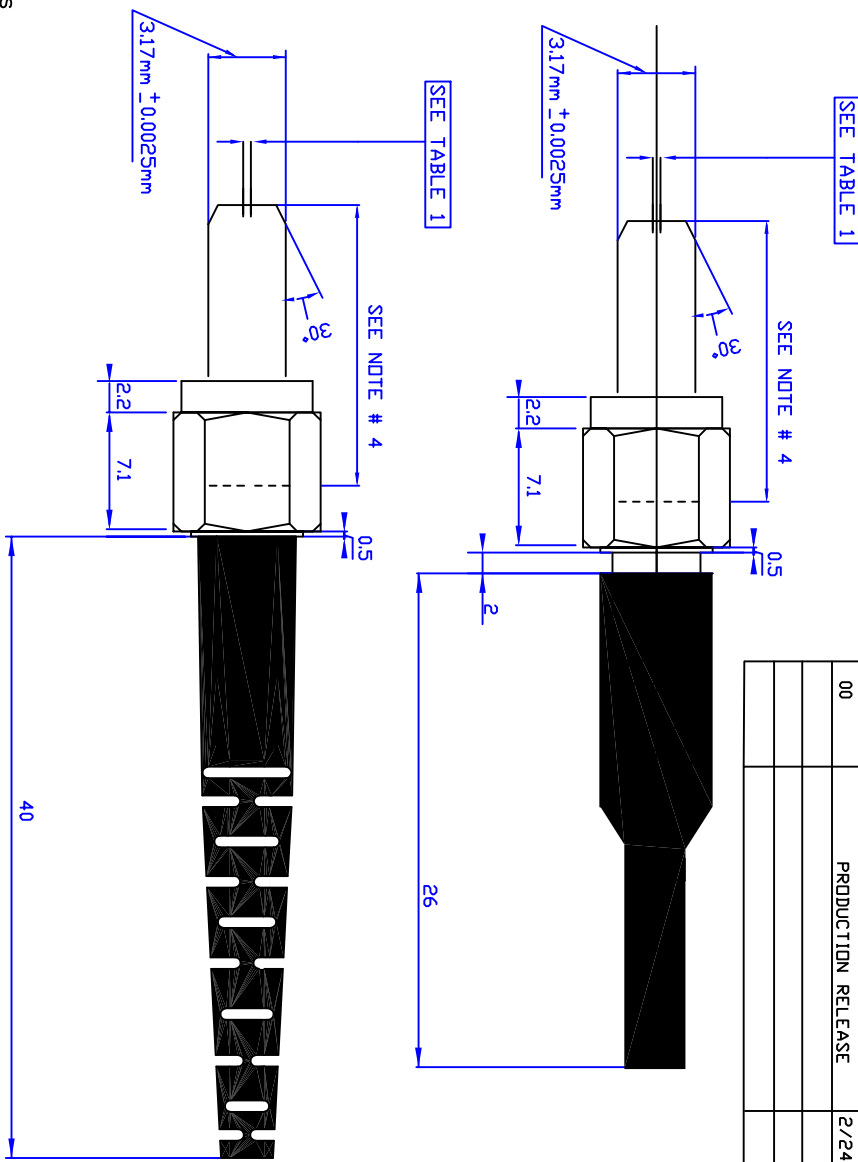

TABLE 1 INSIDE DIAMETER			
I.D.	Min	Max	Concentricity
-XXXX	0.1250	0.1260	0.001
1250	0.1250	0.1260	0.001
1255	0.1255	0.1265	0.001
1260	0.1260	0.1270	0.001

Revisions			
REV	DESCRIPTION	Date	Approved
00	PRODUCTION RELEASE	2/24/08	RP



- NOTES:
1. Body and Nut material: nickle plated brass
 2. Ferrule material: Ceramic (ZrO2)
 3. Boot material: PVC
 4. Ferrule length (protrusion): 10.00mm -0/+0.05 or Can be specified by customer (XX.XXmm -0/+0.05)

Intellectual Property of Precision Fiber Products, Inc. DO NOT duplicate. Return copies upon completion		Precision Fiber Products, Inc SMA 905 Stainless Ferrule w/Hex Nut	
UDS: +/- 0.1mm	Scale:	DWG NO. SM-C0N905HCZ-XXXX	REV 00
MATL: SEE NOTES	Scale:	8/29/11	Sheet 1 of 1