

TABLE 1 INSIDE DIAMETER

-XXX	I.D.	Min	Max	Concentricity
126	0.126	0.126	0.131	<0.01
140	0.140	0.140	0.145	<0.02
150	0.150	0.150	0.155	<0.02
160	0.160	0.160	0.165	<0.02
170	0.170	0.170	0.175	<0.02
175	0.175	0.175	0.180	<0.02
180	0.180	0.180	0.185	<0.02
190	0.190	0.190	0.195	<0.02
200	0.200	0.200	0.205	<0.02
210	0.210	0.210	0.215	<0.02
220	0.220	0.220	0.225	<0.02
230	0.230	0.230	0.235	<0.02
240	0.240	0.240	0.245	<0.02
250	0.250	0.250	0.255	<0.02
255	0.255	0.255	0.260	<0.02
265	0.265	0.265	0.270	<0.02
275	0.275	0.275	0.280	<0.02
280	0.280	0.280	0.285	<0.02
300	0.300	0.300	0.305	<0.02
305	0.305	0.305	0.310	<0.02
330	0.330	0.330	0.335	<0.02
340	0.340	0.340	0.345	<0.02
370	0.370	0.370	0.375	<0.02
400	0.400	0.400	0.405	<0.02
405	0.405	0.405	0.410	<0.02
450	0.450	0.450	0.455	<0.02
455	0.455	0.455	0.460	<0.03
500	0.500	0.500	0.505	<0.03
505	0.505	0.510	0.510	<0.03
530	0.530	0.530	0.535	<0.03
550	0.550	0.550	0.555	<0.03
610	0.610	0.610	0.615	<0.03
650	0.650	0.650	0.655	<0.03
660	0.660	0.660	0.665	<0.03
750	0.750	0.750	0.755	<0.03
810	0.810	0.810	0.815	<0.03
850	0.850	0.850	0.855	<0.03

NOTES:

1. STAINLESS STEEL ALLOY
 CHEMICAL COMPOSITION
 (AVERAGE PERCENTAGES)

Cu	Zn	Pb	Ni	Mn
49.00%	BAL	2.70%	7.25%	2.25%

Revisions

REV	DESCRIPTION	Date	Approved
00	Production Release	11/15/07	RP

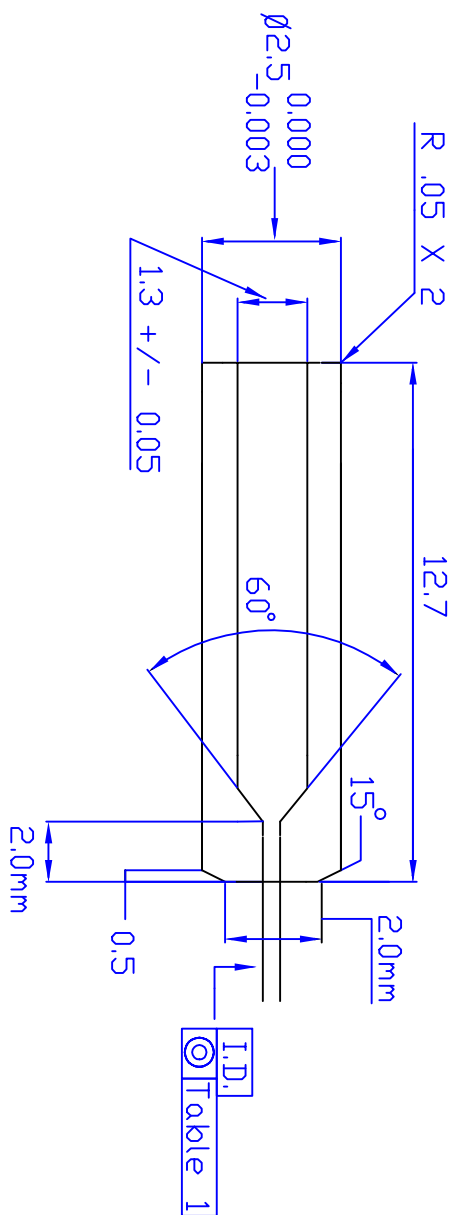

Intellectual Property of Precision Fiber Products, INC. DO NOT duplicate. Return copies upon completion		Precision Fiber Products, Inc	
U.D.S. +/- 0.1mm	Size:	ST 2.5 mm DD Multi Mode Stainless Ferrule	DWG NO: MM-FER-2006SS-XXIX REV: 00
MATL: Stainless Alloy	Scale:		11/15/2007 Sheet 1 of 1